

PROPRIETARY AND CONFIDENTIAL
 THE INFORMATION CONTAINED IN THIS DRAWING IS THE SOLE
 PROPERTY OF ARDENT CONCEPTS, INC. ANY REPRODUCTION
 IN PART OR AS A WHOLE WITHOUT THE WRITTEN PERMISSION OF
 ARDENT CONCEPTS, INC. IS PROHIBITED.

REVISIONS			
REV.	DESCRIPTION	DATE	APPROVED
A	RELEASED, ECN19-3235	10/31/19	SD
B	CORRECTED O'ALL HEIGHT	12/18/19	SD
C	UPDATED PINOUT	01/27/20	SD
D	ADDED NUTS, SHIPPING COVER	02/07/19	SD
E	UPDATE FOR HVM	03/11/20	SD
F	RELEASED, ECN20-4097	04/02/20	SD
G	ECN20-4192, 1.50mm WAS 1.00mm	06/18/20	SD
H	UPDATE HARDWARE	07/30/20	SD

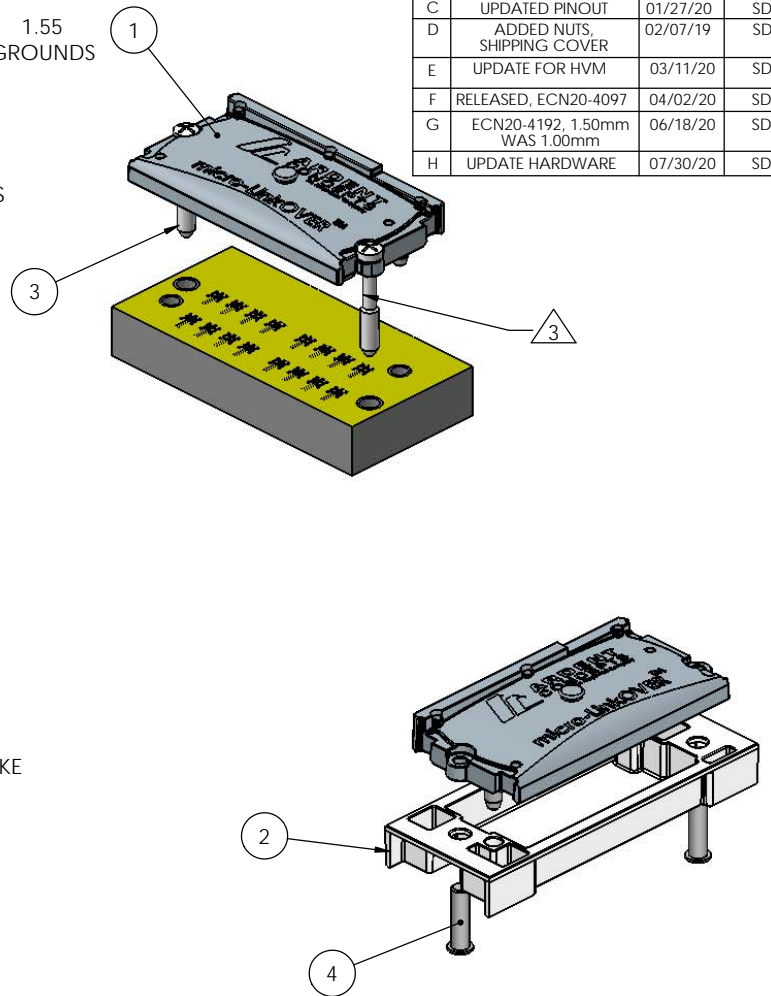
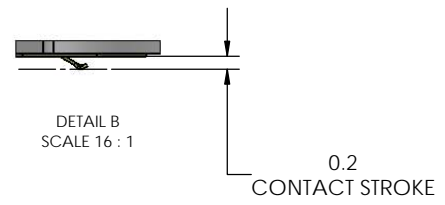
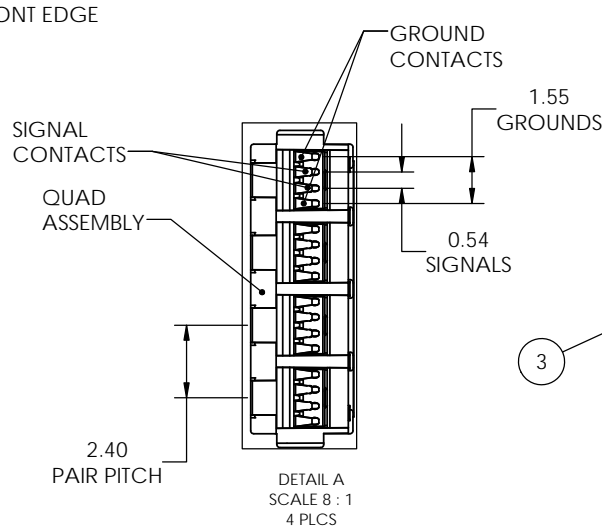
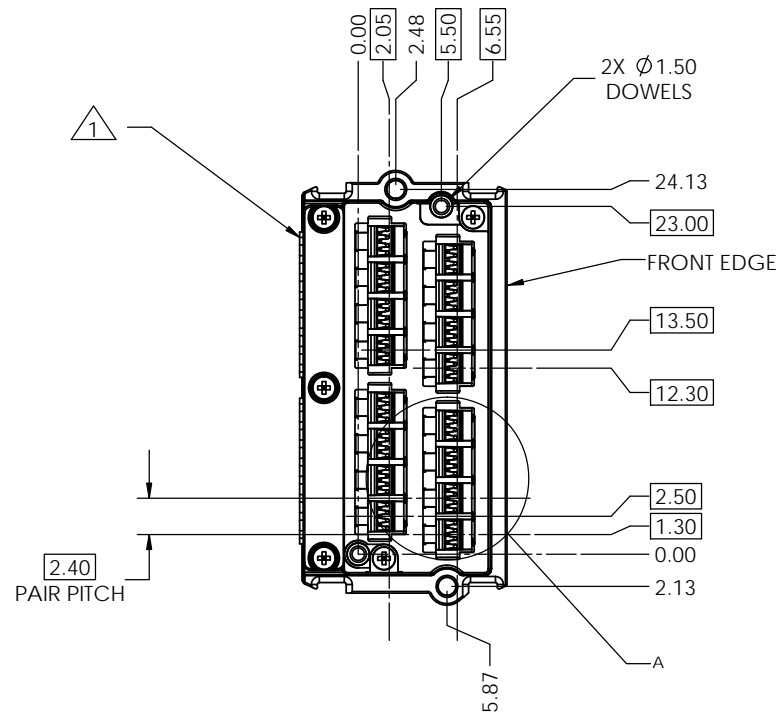
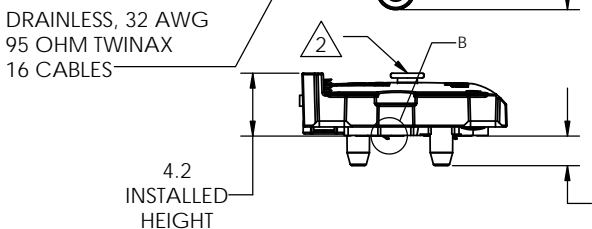
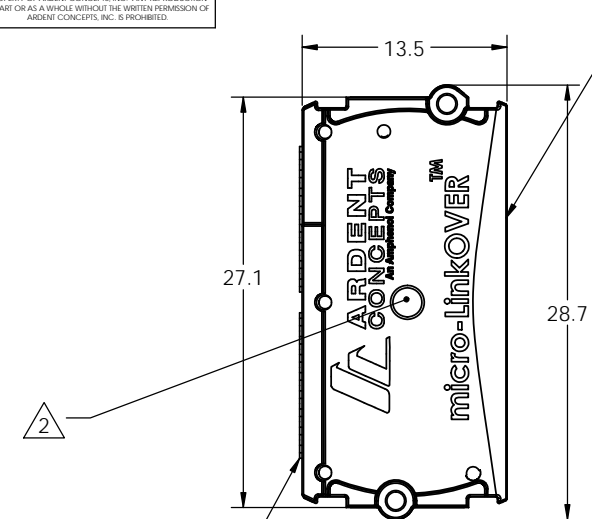

ITEM NO.	PART NUMBER	DESCRIPTION	SEATED/SCREW-MOUNT SEATED/QT.Y.
1	mLO-CON-S16X2-XXX-S-01	16 Pair micro-LinkOVER Connector, Screw Mount	1
2	mLO-AC-16X2-01	ANCHOR CARRIER	2
3	M16CPHCS10	M1.6 CAPTIVE PAN HEAD X 10mm	4
4	M16PHCS06	M1.6 PAN HEAD X 6mm, 96773A625	4
5	mLO-FP-16X2-01	16 PAIR micro-LinkOVER FOOTPRINT SPECIFICATION, SCREW MOUNT	REF

- NOTES:
- XXX INDICATES CABLE LENGTH IN mm.
 - FLATTEN FLAT SPRING BUTTON.
 - CAPTIVE SCREWS SHIP SEPARATELY.

CHANGE	NOTE	PROJECTION	METRIC UNLESS OTHERWISE SPECIFIED. TOLERANCES: ANGLES: ±3 X.X = ±1 X.XX = ±05 X.XXX = ±025	 4 MERRILL INDUSTRIAL DRIVE, SUITE 102 HAMPTON, NH 03842 (603) 474-1760		
MATERIAL	SIZE	TITLE:	16 PAIR micro-LinkOVER, SCREW MOUNT DWG. NO. mLO-S16X2-XXX-S-01 REV H			
FINISH		INTERPRET GEOMETRIC TOLERANCING PER: ANSI Y14.5M 1982	WWW.ARDENTCONCEPTS.COM	SCALE: 4:1	WEIGHT:	SHEET 1 OF 2

PROPRIETARY AND CONFIDENTIAL
 THE INFORMATION CONTAINED IN THIS DRAWING IS THE SOLE
 PROPERTY OF ARDENT CONCEPTS, INC. ANY REPRODUCTION
 IN PART OR AS A WHOLE WITHOUT THE WRITTEN PERMISSION OF
 ARDENT CONCEPTS, INC. IS PROHIBITED.

P1	P2
B1	> F16
B2	> F15
B3	> F14
B4	> F13
B5	> F12
B6	> F11
B7	> F10
B8	> F9
B9	> F8
B10	> F7
B11	> F6
B12	> F5
B13	> F4
B14	> F3
B15	> F2
B16	> F1
F1	> B16
F2	> B15
F3	> B14
F4	> B13
F5	> B12
F6	> B11
F7	> B10
F8	> B9
F9	> B8
F10	> B7
F11	> B6
F12	> B5
F13	> B4
F14	> B3
F15	> B2
F16	> B1

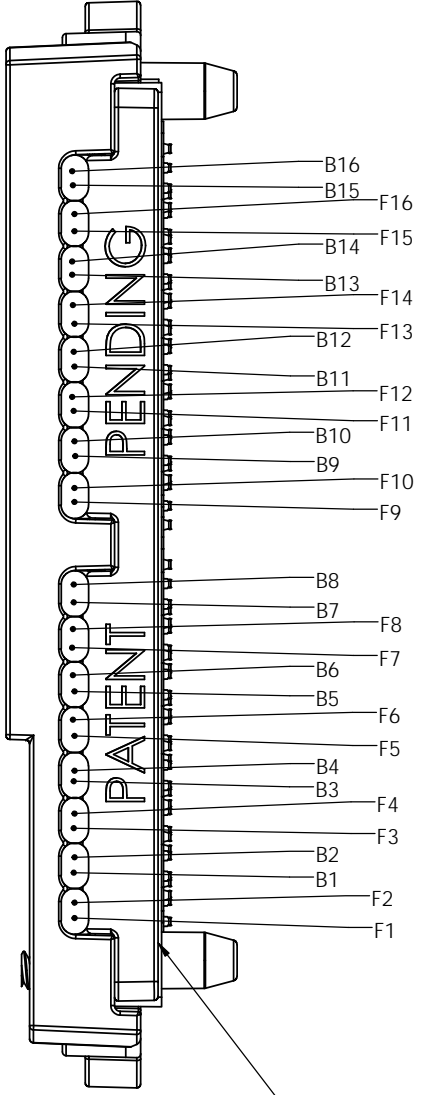

**P1 TO P2
CABLE ROUTING**

PCB SIDE

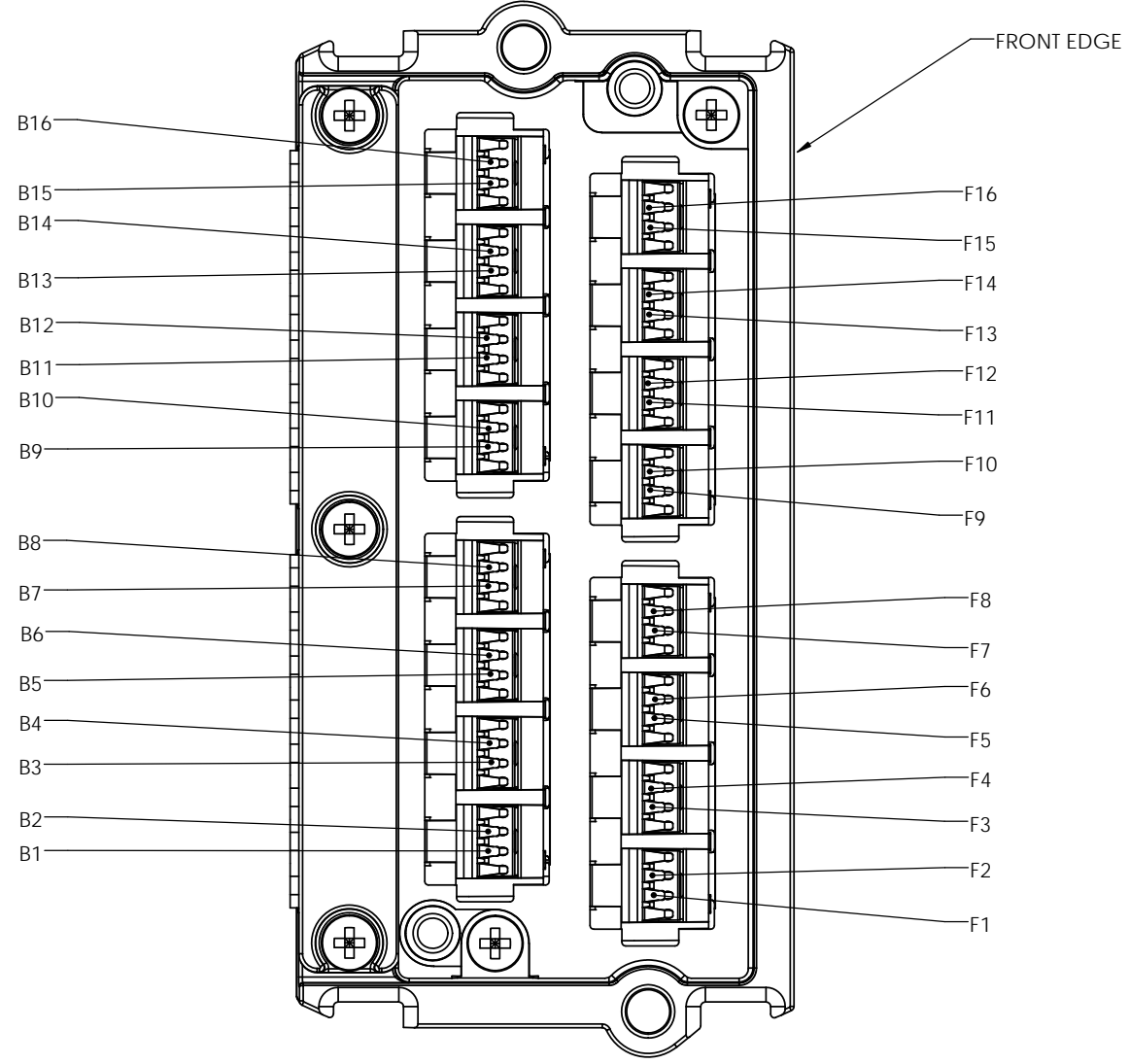

BOTTOM SIDE VIEWED FROM THE BOTTOM
PINOUT CONVENTION

CHANGE NOTE PROJECTION	METRIC UNLESS OTHERWISE SPECIFIED. TOLERANCES: ANGLES: ±3 X.X = ±1 X.XX = ±0.05 X.XXX = ±0.025		 ARDENT CONCEPTS <small>INCORPORATED</small> 4 MERRILL INDUSTRIAL DRIVE, SUITE 102 HAMPTON, NH 03842 (603) 474-1760
	MATERIAL: -- FINISH: --	SIZE: C INTERPRET GEOMETRIC TOLERANCING PER: ANSI Y14.5M 1982	